

NOTE:
SUITABLE FOR RECTANGULAR PENETRATIONS UP TO 1200mm WIDE.
ROOF PITCH MUST BE 10° or HIGHER - REFER TO E2/AS1 TABLE 9 or 17 FOR MAX. ROOF LENGTH ABOVE PENETRATIONS. BLOCKING REQUIRED FOR PENETRATIONS OVER 200mm

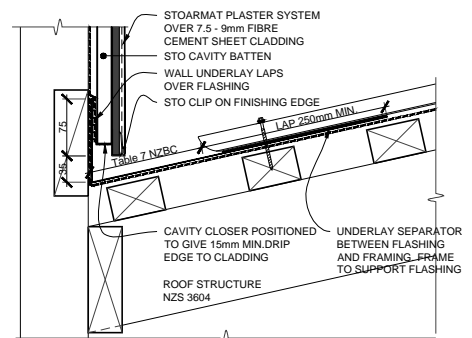
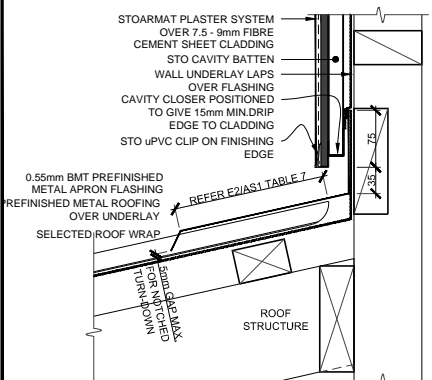

STO POREN SYSTEM	STO POREN PANEL CLADDING SYSTEM	PP 710
	FRAMED CHIMNEY	2014

The information contained in this detail is based on our experience and testing and represents the latest information available at the date of issue. This detail is intended for use by the design professional and users of Sto products to assist in developing specific project details to be used in conjunction with a Sto Specification. We reserve the right to alter or update information at any time without prior notice & it is the responsibility of the specifier and/or the project manager to insure that they have the current Sto details and specifications.